

- Designed for 2.4" Three Phase Laminations.
- Use Part Number 3P240EMB for ordering mounting brackets
- Weight – 45 lbs.

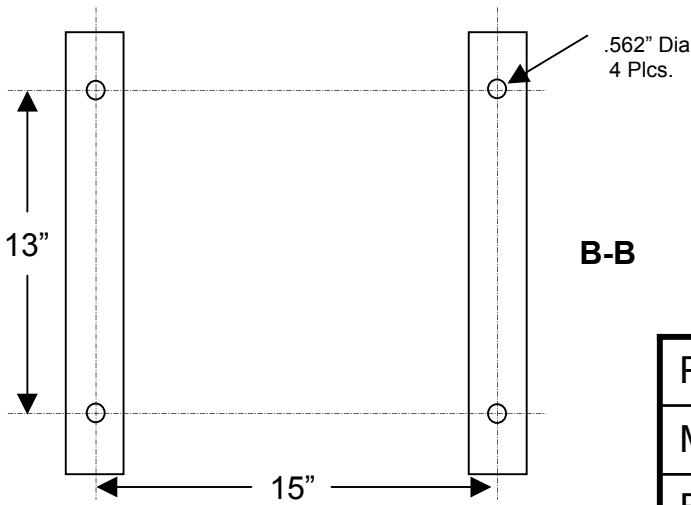

NOT TO SCALE



Part Number 171722N1
Material: 16 gauge C.R. Steel
Finish: Bay Fog Gray Powder Coat